



SCHAEFF

Produced by KAEUBLE GmbH

PERFECT IN TUNNELING

**TUNNEL EXCAVATORS TE210
DIESEL & TE210E ELECTRO**



UNCOMPROMISING TUNNEL HEADING MACHINE

Tunnel heading is extremely hard work. Each project is as an expedition to undiscovered regions under the earth surface. What matters here is the perfect team of people and machinery. For that reason CMT offers you only the Best Equipment.

CMT tunnel excavator TE210, either with a diesel engine or with an electric drive, goes ahead due to its enormous power, breaking through any wall. The boom equipment, in combination with the slewing shovel arm, develops strong breakout forces, and, hence, the breakout is relevant to the profile requirements. In the course of this the driver is in a position precisely to control each working movement. Numerous work attachments enable TE210 to work out the desired profile.

A CMT tunnel excavator is never an ordinary excavator. The CMT tunnel excavator does things that no ordinary excavator can do.

TE210 / TE210E

Operating weight	28 - 32 t
Driving power	Diesel · 165 kW Electro · 132 kW (400 V)
Recommended operational cross section	25 - 60 m ²
Breakout force	140 kN
Ripping force	100 kN

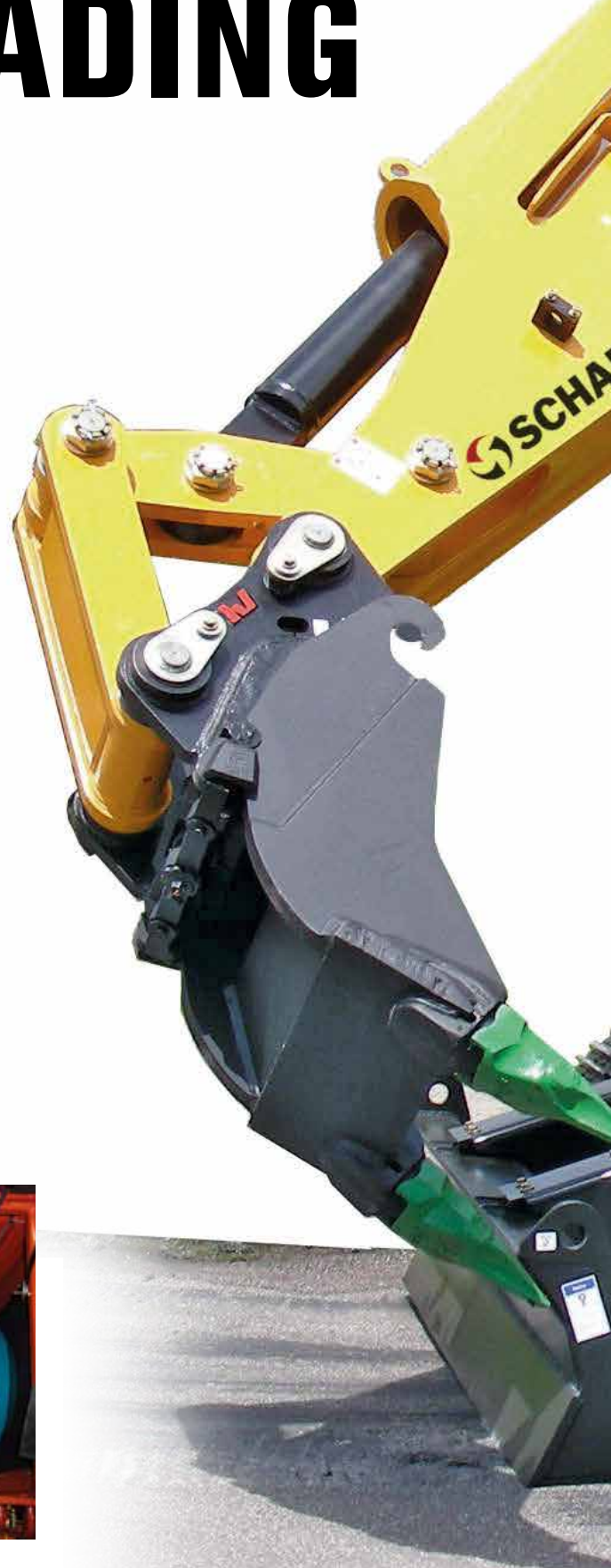

**A PRODUCT THAT
OFFERS MANY BENEFITS**

Functional range	4
Benefits	6
Boom and Driver's platform	8
Undercarriage and electric drive	10
Attachments	12
Transport	14
Technical data TE210	16
Technical data TE210 E	18



A HERO AT WORK

Nothing can stop a T210. Meter by meter and in direct propulsion, T210 advances and clears after the tunnel drilling machines, profiling by drilling and blasting.



COMPACT DESIGN

With a short rear for maximum slewing area also in narrow tunnels.

TE210 reveals its strengths on soft to medium hard ground. Due to the compact design and the enormous reach, even if overhead works are carried out, TE210 is extremely suitable for small and middle-sized cross sections.



ELECTRICALLY DRIVEN TUNNEL EXCAVATOR

For special use, e.g. tunnel heading under air pressure, or if special, emission-free application is required



ROTARY CUTTER OPERATION

Exact profiling, incl. at overhead work



HAMMER OPERATION

With regard to the hydraulics, the factory settings are preset for the application of a hammer up to 1.5 tonnes.

CUTTING PERFECTION

OPTIMAL FOR TUNNEL CROSS SECTIONS FROM 4.7 TO 9 M

**WIDER SCOPE:
LONGER SHOVEL ARM**

Shovel arm: 3780 mm
Removable shovel with quick coupler CW40

**SHORT AND MANOEUVRABLE:
SHORTER SHOVEL ARM**

Shovel arm: 2880 mm
Rotary cutter WS90 N with quick coupler CW40

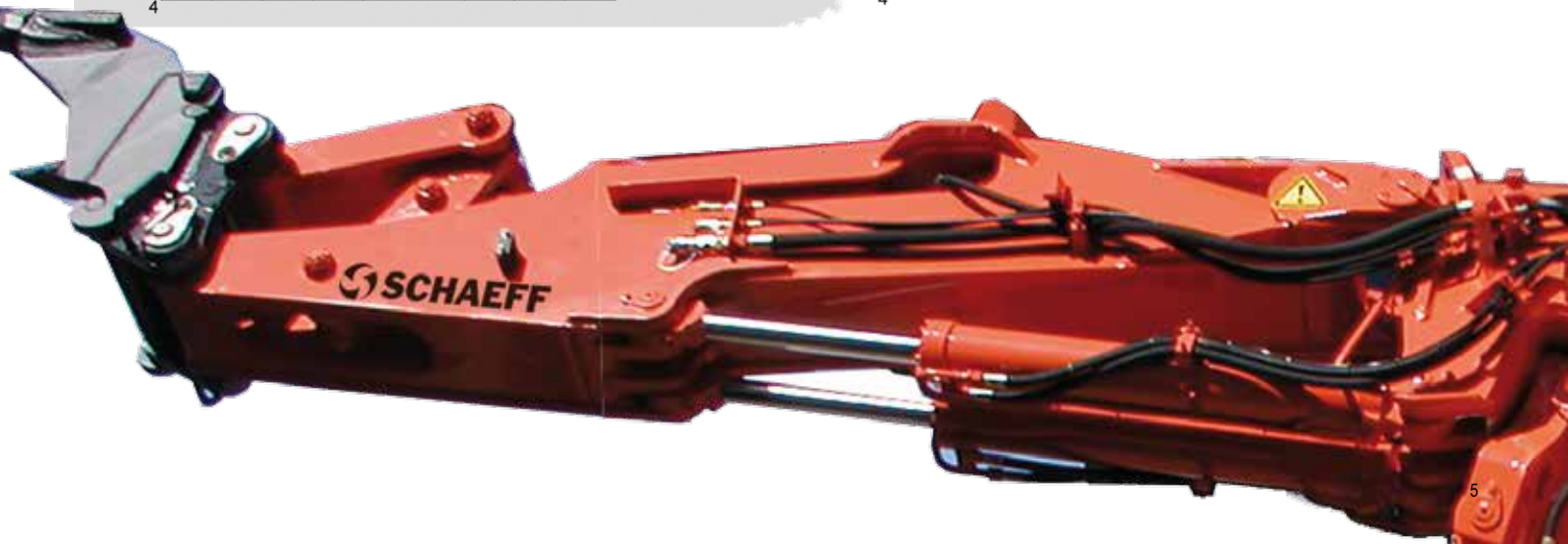
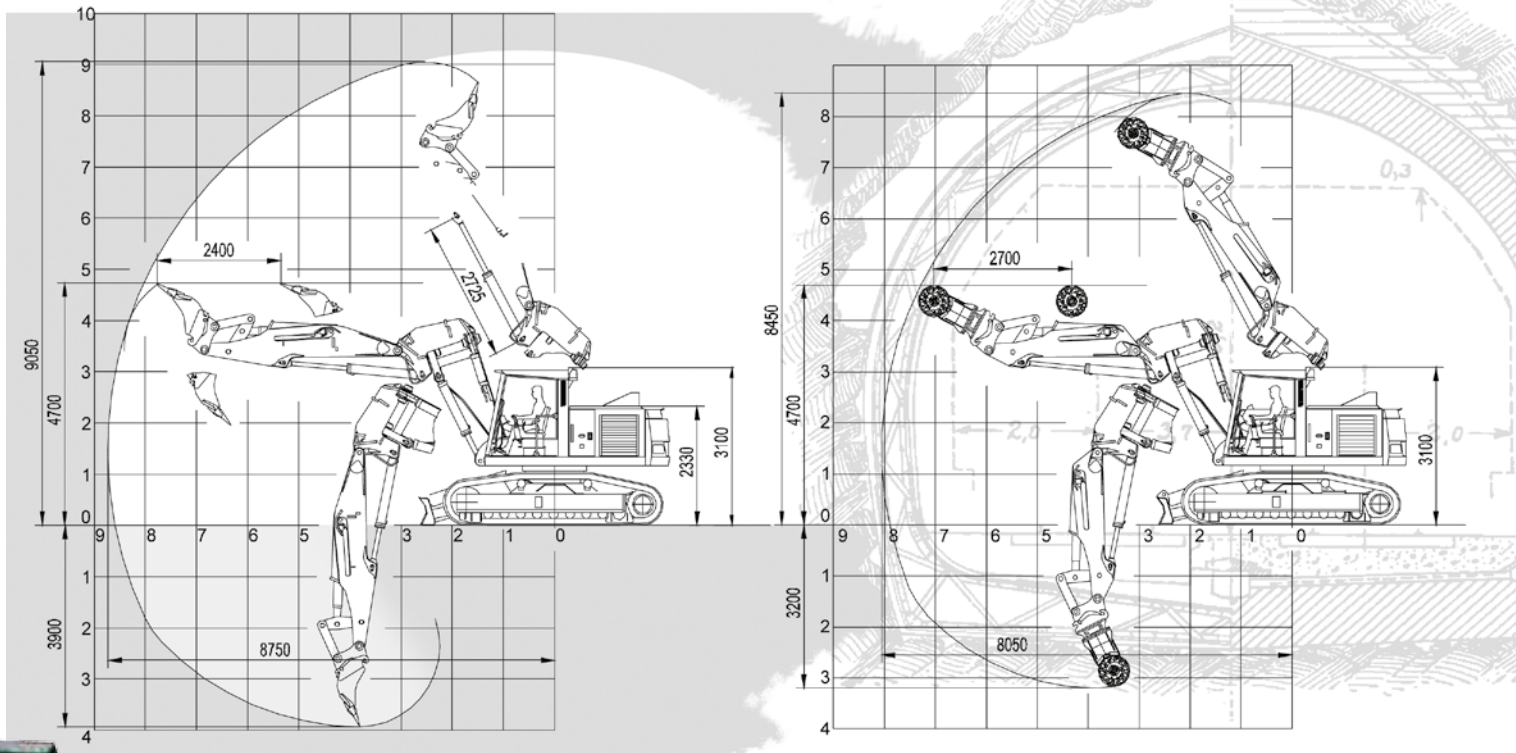

HEAVY METAL!

So many benefits - that sounds good.
The benefits turn TE210 to a successful model.

ATTACHMENTS

- With regard to the hydraulics, the factory settings are preset for the application of rotary cutters up to 90kW, hammers up to 1.5 tonnes, and demolition shears / pulverisers up to 2.5 t class.
- Mechanical or hydraulic quick attachments are also available.

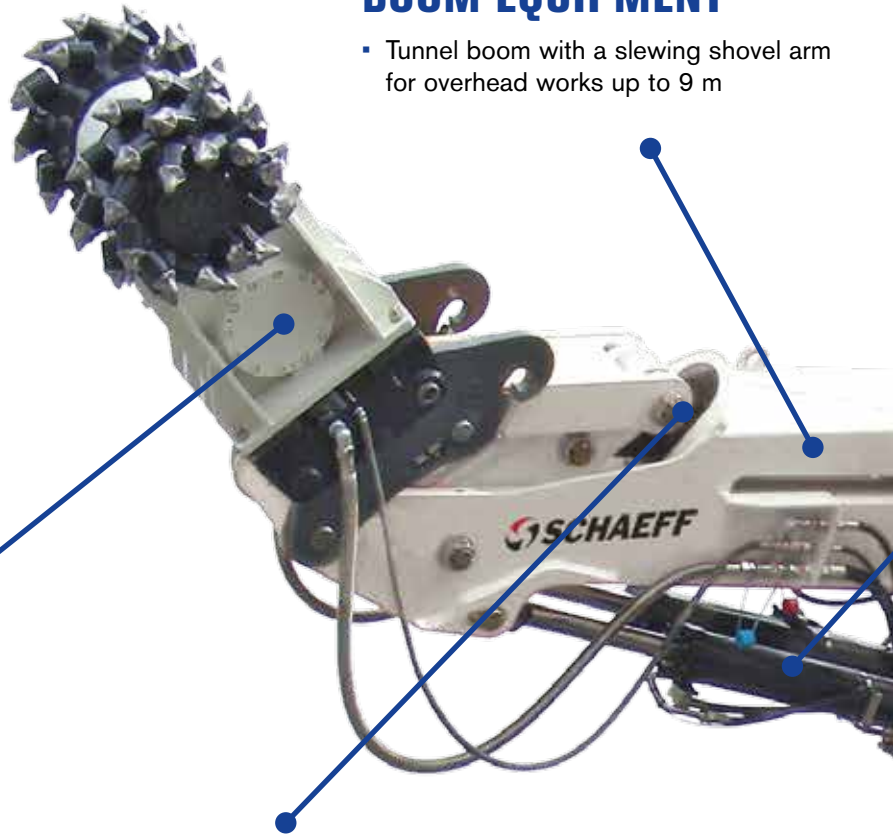

BOOM EQUIPMENT

- Tunnel boom with a slewing shovel arm for overhead works up to 9 m

SHOVEL CYLINDER

- Shovel cylinder with an extremely large cylinder tube and a special guide link

HYDRAULICS

- Load sensing hydraulic for proper and cost-effective excavator operation

UNDERCARRIAGE

- High-performance drive, either via a diesel engine with a diesel particulate filter (165 kW) or emission-free electric motor (132 kW)
- Enormous gradability for applications with extreme inclinations

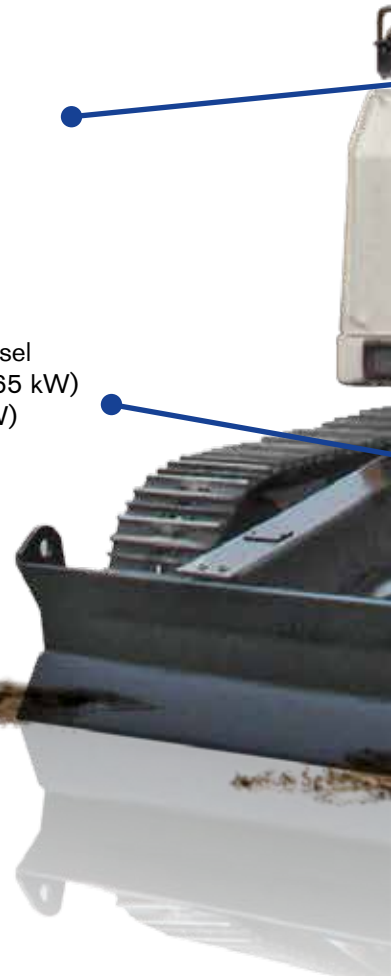

DOUBLE LIFTING CYLINDER

- Robust double lifting cylinder for tunnel construction

DRIVER'S PLATFORM

- Two cameras for optimum overview to the right side and backward

ADDITIONAL WEIGHT

- Two tonnes additional extra weight as adjustable ballast for special applications

REVERSIBLE FAN

- The hydraulic reversible fan is temperature-controlled and starts automatically if required.
- Manual reverse function

UPPERCARRIAGE

- Robust box-type design for high loading capacity

CHAIN TRACK

- Chain track with 2., 3. or 4. bar plate is also possible
- Maintenance-free tractor running gear



DESIGNED FOR TUNNEL CONSTRUCTION

THE BOOM AND THE DRIVER'S PLATFORM

POWERFULLY AND COMFORTABLY THROUGH THE ROCK

THE BOOM: RESISTANCE IS FUTILE

The especially strong boom equipment and the special cinematics develop extraordinary breakout forces and are ideal for obtaining of precisely profiled final results.

Double power is available only with TE210: Both the shovel arm and the lifting boom work with a „Made in Germany“ double lifting cylinder, so as to ensure your work with a reliable and quality tool.

Optimal hydraulic power via a load sensing system

The pump output adjusts automatically to consumer's needs - the machine works efficiently during all work cycles. We use only hydraulic hoses as they are much more easier to replace than the tubes.



The central lubrication system is designed as per standard for quick daily service. Any of the main bearing point presents a floating suspension, so as to ensure self-lubrication, to reduce wear and to enable easy assembly and disassembly.



THE DRIVER'S PLATFORM: EVERYTHING UNDER CONTROL

The driver's platform is a special construction designed for tunnel structures. The driver has a clear view both to the relevant attachment and to the field of application. The video system enables the driver to observe the situation alongside and behind the machine. The adjustable comfort seat is size and weight-adjustable and reduces fatigue.

Just in case

The driver's seat meets the requirements for a roll-over and falling-object protective structure, i.e. the ROPS/FOPS standards. The entire electronic equipment is protected to IP55 degree of protection, i.e. it is protected from dust and spray water.

Cab

If necessary, we are in a position to deliver a closed cab. Cabs are available either with a 9 mm safety glass or with scratch resistant plastic windows. The cab is available with pressure ventilation (as a standard) and an air-conditioning system (optionally). The cab is additionally protected by a metal grill on top.

THE DRIVE AND THE UNDERCARRIAGE

UNSTOPPABLE THANKS TO THE PERFECT DRIVE SOLUTIONS

THE UNDERCARRIAGE: RELIABLY UNSTOPPABLE

Robust construction

The undercarriage is an extremely robust construction. The travel drive and the cylinder at the dozer blade are protected against damage. Optionally, it is possible to order the main components made of fine-grained steel.

100% Climber

Due to the first-class climbing properties TE210 achieves a gradability of 100 %.

Chain track

Chain widths from 400 to 500 mm.



Railroad wheel set

TE210 re-railing over long distances is possible via the optional railroad wheel set.

Maintaining flexibility

Depending on whether a small overall width or increased work force is required, the floor plate is available in a width of 400 mm or 500 mm.





THE ELECTRIC DRIVE: MISTER 400 VOLTS

The emission-free electric drive with 132 kW enables TE210 to work effectively also in sensitive areas. You may choose to run the engine either with 400 or 1000 V. The cable reel is mounted on the undercarriage so as to retain its full 360° slewing range. A cable length of 60 m offers sufficient room for manoeuvre, the cable however is provided with a safety shutdown if the maximum length is reached.

FLEXIBLE IN USE

TE210 may be run with a wide variety of accessories. The high hydraulic power enables the application of extremely powerful attachments. The essential additional two control circuits are designed as per standard.

ROTARY CUTTERS: HIGH CUTTING PERFORMANCE

Rotary cutter suitable for any kind of tunnel application: for a breakout of a precise contour, as well as for a profile-following wall surface cutting. We construct our tunnel rotary cutters by ourselves: efficient, resistant to wear and economical in operation.

RIPPER BUCKET: EXTREMELY ROBUST CONSTRUCTION

Ripping forces are transferred at the best possible rate in ripper-bucket mode. Ripper-bucket mode is especially suitable for rock outbreak and ripping because of bucket's special form and digging behaviour.



CUTTER BUCKET: POWERFULL COMBINATION

Excavating, cutting, crushing, mixing: all in one working operation. There is no need to change the tool. This saves time and increases productivity.

HAMMER: FULL STRIKING FORCE

Perfect break through via our hammers: the high striking force through the entire speed range ensures rapid progress. The extremely solid construction ensures minimal standstill. Central lubrication of the hammer as standard.

SPECIAL: TUNNEL QUICK COUPLER

Mechanical quick coupler as standard for a simple change of tools.

DEMOLITION SHEARS

The demolition shears and the pulveriser are available up to the 2.5 t class.



IT GOES DOWN EXTREMELY WELL



EASY TRANSPORTATION BELOW GROUND

TE210 can be disassembled into 25 separate components. In the event of narrow gates the driver's platform can be shortened so as to enable TE210 to come through. Shortening increases TE210 flexibility of use.

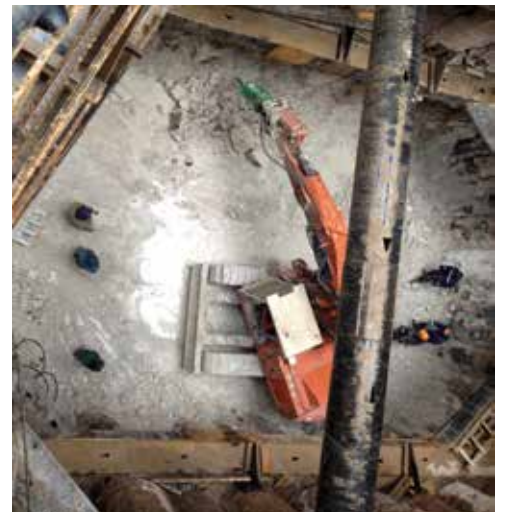

IDEALLY SITUATED FOR TRAVELLING



Cost-effective transport

TE210 permits cost-effective transportation on a flatbed truck, including the boom equipment. For the purposes of underground works the machine can be disassembled and on site re-assembled.

Easy refuelling

...in the tunnel, by means of a refuelling pump - as standard for diesel, optionally for hydraulic oil.

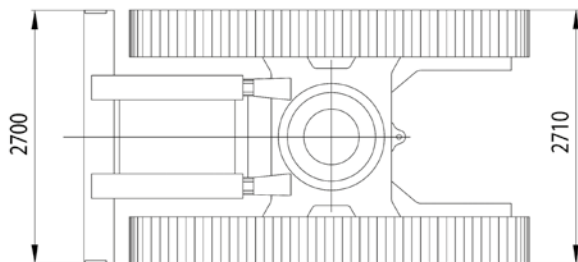
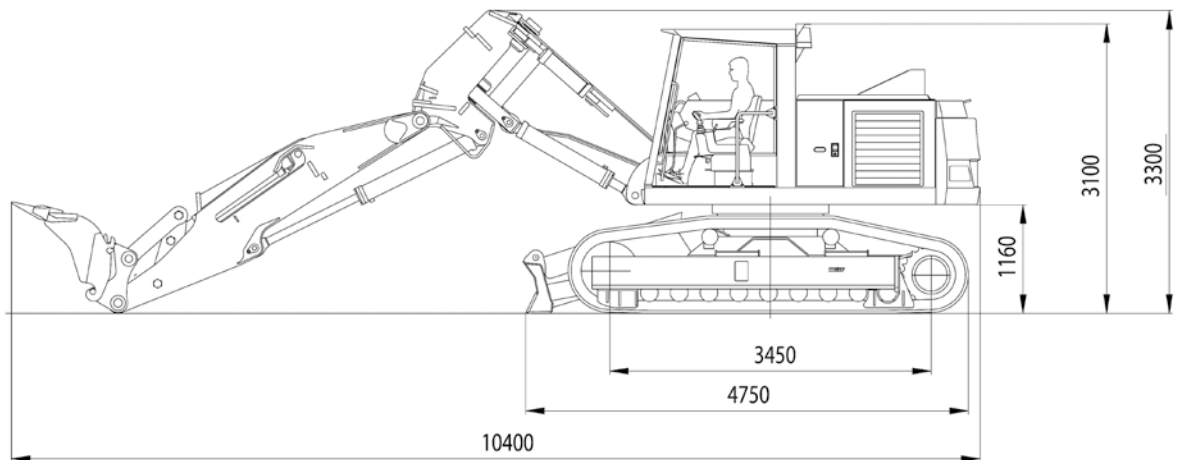

FUNCTIONAL RANGE:

Operating parameters

- Max. vertical reach: 8.500 mm
- Max. digging depth: 3.900 mm
- Min. working height: 4.700 mm
- Min. overhead clearance: 3.300 mm
- Machine width - undercarriage: 2.500 mm
- Machine width - uppercarriage: 2.700 mm
- Machine height (over cab protective roof): 3.100 mm
- Machine height for transportation: 3.300 mm
- Rear slewing radius: 2.250 mm
- Min. slewing radius: 3.670 mm
- Operating weight (depending on the equipment): approx. 28 t

Diesel drive

Water-cooled turbocharged diesel engine

Deutz TCD 2013 L06 2V

- Power rating at 2'000 UPM 165 kW
- The diesel engine complies with the exhaust emission standard EEC Euro St. 3a Optionally - diesel engine according to Euro St. 3b, Deutz TCD 7.8
- Fuel tank capacity: 410 l
Optionally: tunnel excavator TE 210 with the reliable and emission-free electric drive with 132 kW electric motor.

Certification for tunnel construction

The machine meets the current CE-requirements and is certified for tunnel construction according to EN 12111, Dec. 2002.

Hydraulic system

- Hydraulic facility: Output controlled dual axial piston pump with „load-sense“ control
- Pump capacity: 520 + 90 l/min
- Hammer/Rotary cutter control circuit 280 l/min
- Hydraulic operating pressure: max. 350 bar
- Hydraulic oil filling quantity (incl. the facility): approx. 450 l
- Hydraulic oil tank capacity: approx. 370 l
- Hydraulic oil filter: full-flow return filter with a contamination indicator
- Filter finesses: 10 µm



Crawler-type undercarriage

- Crawler chain type: Maintenance-free tractor running gear type D 6
- Chassis width: 2.700 mm
- Chassis length: 3.450 mm
- Standard floor plate width: 400 mm (optionally 500 mm)
- Hydrostatic travel drive via of 3-stage planetary gear with a hydraulic parking brake, as well as driving engines with integrated brake valves.
- Travel speed: 0 - 1.7 / 4.5 km/h
- Crawler tractive power: 280 kN
- Gradability: max. 100%

Boom equipment

- Type: special tunnel boom
- Main boom: with a double lifting cylinder and slewing gear 2x45°
- Shovel arm with a double lifting cylinder and an integrated shovel cylinder
- Shovel arm length: 3.780 mm
- Shovel arm feed motion (in 4.7 height): 2.400 mm
- Standard ripper bucket: 660 mm wide with 2 teeth Esco V51
- Shovel radius: 1.175 mm
- Ripping force: 100 kN
- Breakout force: 140 kN

WITH A SHOVEL:

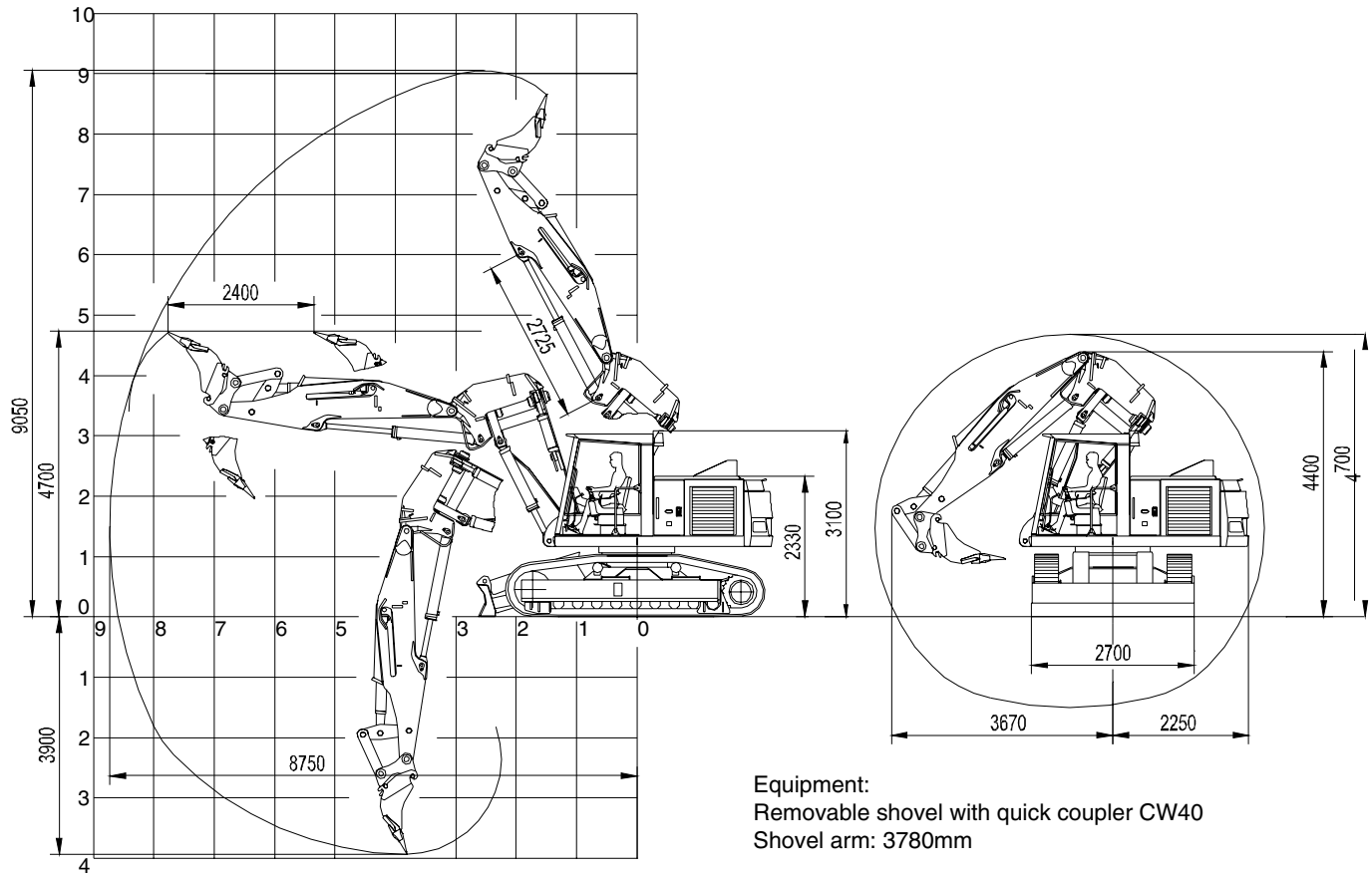

WITH A ROTARY CUTTER:

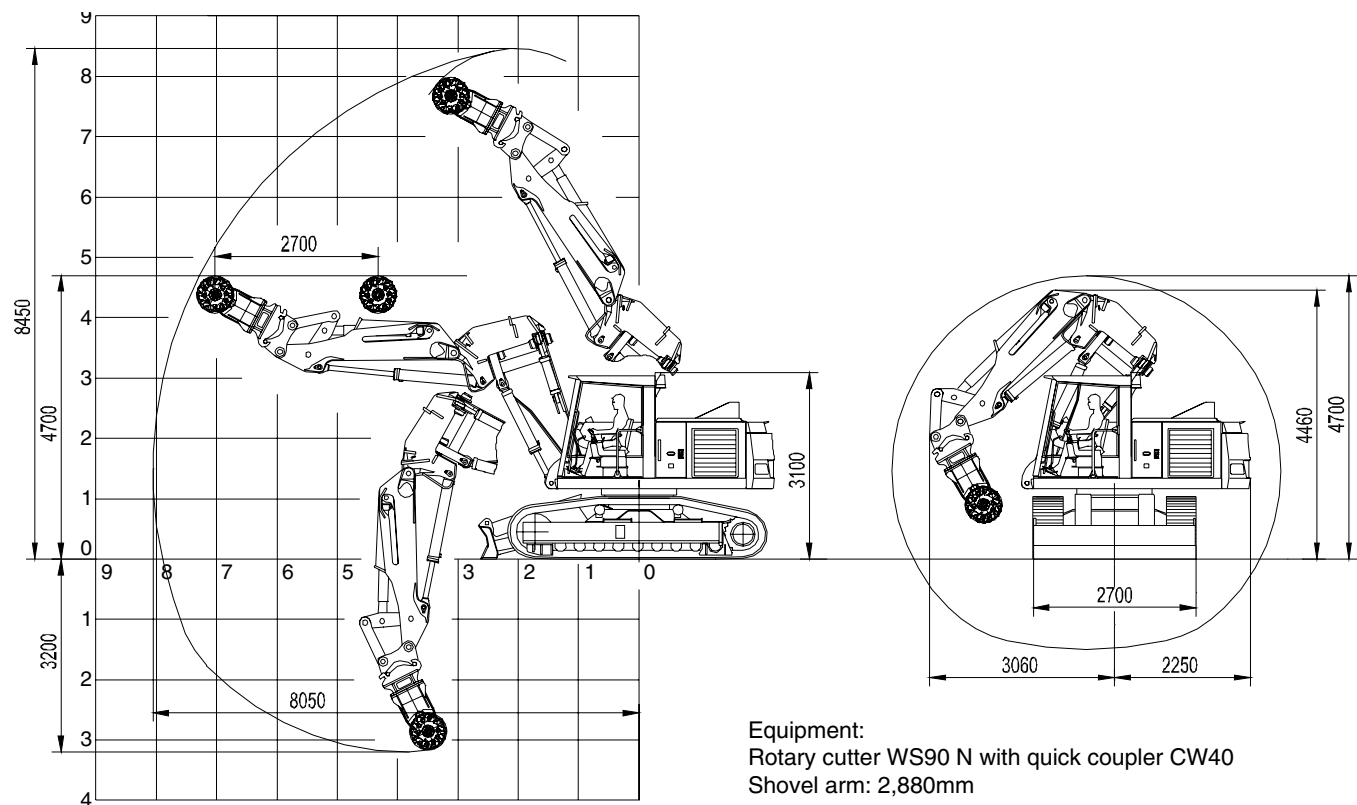

FUNCTIONAL RANGE:

Operating parameters

- Max. vertical reach: 9.050 mm
- Max. digging depth: 3.900 mm
- Min. working height: 4.700 mm
- Min. Overhead clearance: 3.300 mm
- Machine width (Uppercarriage): 2.500 mm
- Machine width (Undercarriage): 2.700 mm
- Machine height (over cab protective roof): 3.100 mm
- Machine height for transportation: 3.300 mm
- Rear slewing radius: 2.250 mm
- Min. slewing radius: 3.670 mm
- Operating weight (depending on the equipment): approx. 28 t

Electric drive

Driving power rating at 400 Volt, 50 Hz: 132 kW

- RPM (50 Hz): 1480 Upm
- Nominal torque: 851 Nm
- Rated current (400 V) 251 A

If desired, tunnel excavator TE 210 E may be modified to an excavator with a conventional diesel drive fitted with a water-cooled 165 kW Deutz turbocharged diesel engine and a diesel particulate filter system.

Certification for tunnel construction

The machine meets the current CE-requirements and is certified for tunnel construction according to EN 12111, Dec. 2002.

Hydraulic system

- Hydraulic facility: Output controlled dual axial piston pump with 'load-sense' control
- Pump capacity: 380 + 140 l/min
- Hammer/Rotary cutter control circuit 280 l/min
- Hydraulic operating pressure: max. 350 bar
- Hydraulic oil filling quantity (incl. the facility): approx. 380 l
- Hydraulic oil tank capacity: approx. 330 l
- Hydraulic oil filter: full-flow return filter with a contamination indicator
- Hydraulic filter: 10 µm



Crawler-type undercarriage

- Crawler chain type: Maintenance-free tractor running gear type D 6
- Chassis width: 2.700 mm
- Chassis length: 3.450 mm
- Standard floor plate width: 400 mm (optionally 500 mm)
- Hydrostatic drive by means of 3-stage planetary gear with a hydraulic parking brake, as well as driving engines with integrated brake valves.
- Travel speed: 0 - 1.7 / 5.0 km/h
- Crawler tractive power: 280 kN
- Gradability: max. 100%

Electrical equipment

- Electric voltage: 400V/50 Hz
- Electrical system: acc. to DIN EN 60439 and VDE113
- Control electrics: 24 V DC
- Safety installation: Visual and acoustic warning if limit values are exceeded: hydraulic oil temperature, oil level, contamination of hydraulic oil filter.

Cable reel

- Cable reel of undercarriage
- Cable drum with a hydrostatic drive and an automatic cable reel device
- Storage capacity: 60 m
- Cable type: Buflex M, 3x120 + 3x25 mm²

Boom equipment

- Type: special tunnel boom
- Main boom: with a double lifting cylinder and slewing gear 2x45°
- Shovel arm with a double lifting cylinder and an integrated shovel cylinder
- Shovel arm length: 3.780 mm
- Shovel arm feed motion (in 4.7 height): 2.400 mm
- Standard ripper bucket: 660 mm wide with 2 teeth Esco V51
- Shovel radius: 1,175 mm
- Ripping force: 100 kN
- Breakout force: 140 kN

WITH A SHOVEL:

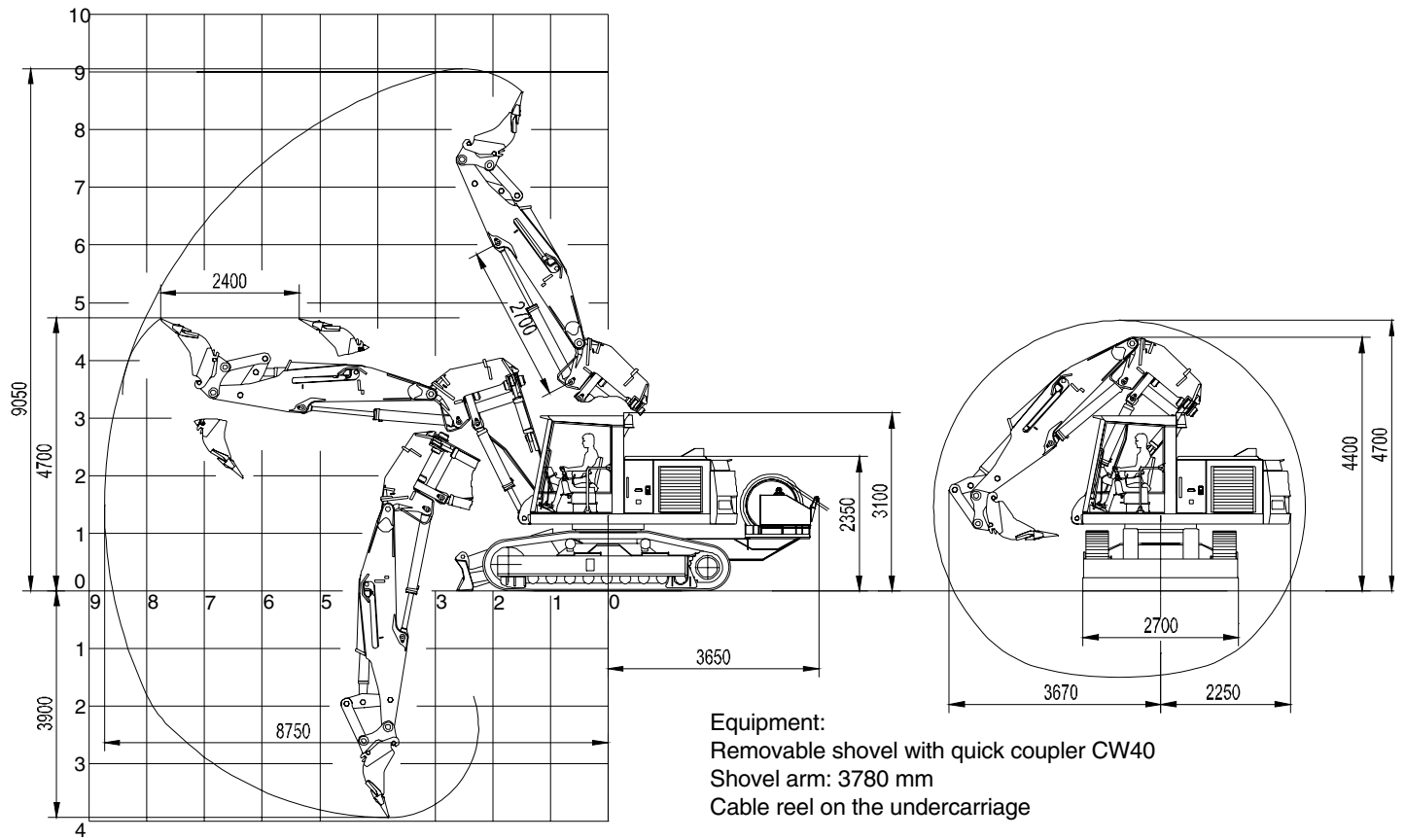

WITH A ROTARY CUTTER:

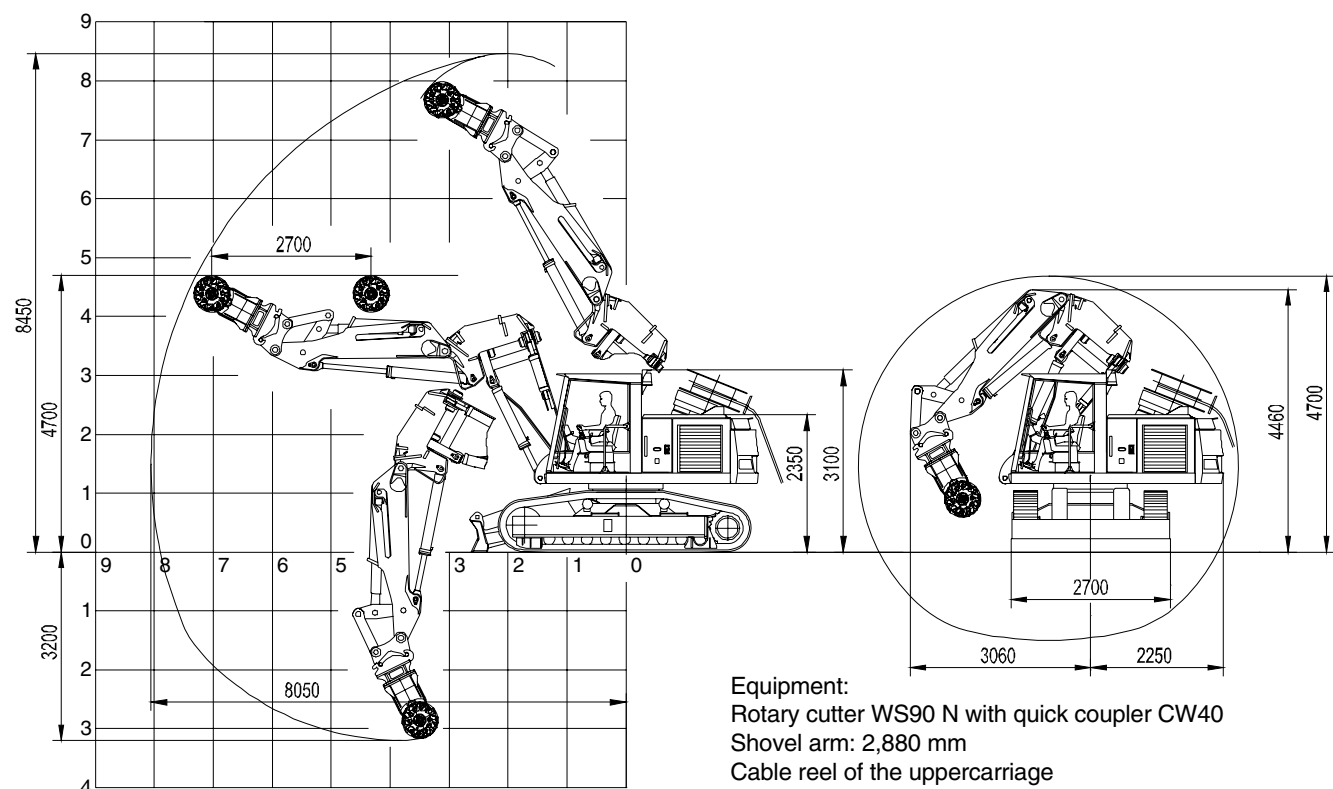



SCHAEFF

Produced by KAEUBLE GmbH

WORLDWIDE IN USE

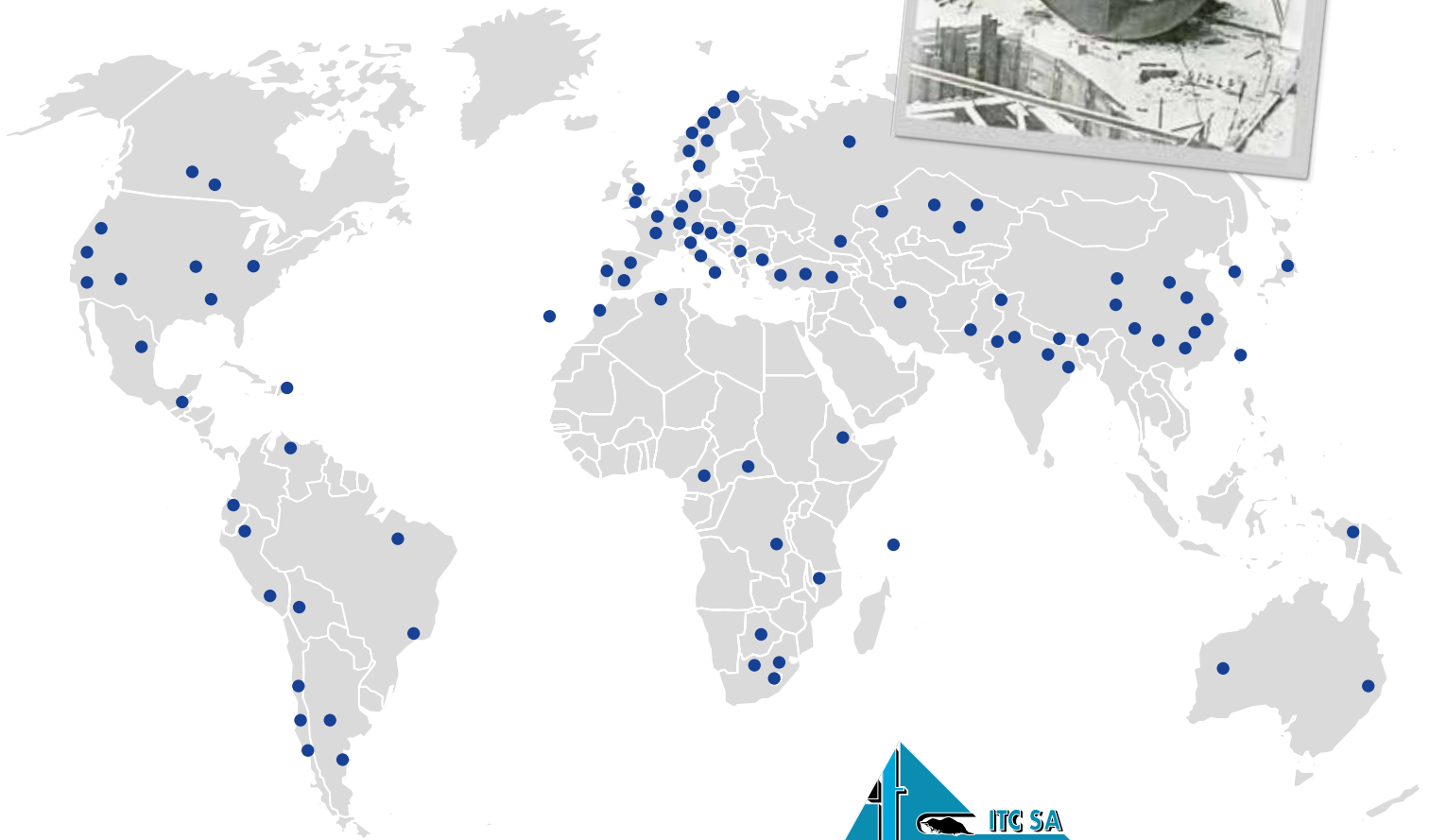
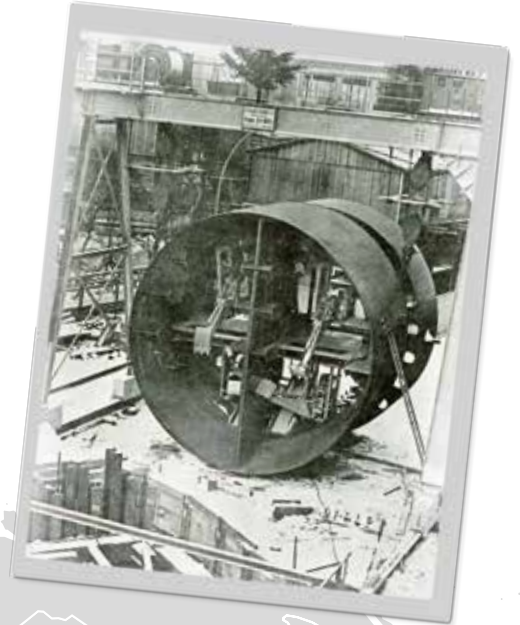

KAEUBLE GmbH
CMT
HFM
Cylinders
Steel Fabrication

Daimler Straße 5-6,
D-74582 Gerabronn
Deutschland
T: +49(0)7952 606 60
E: info@kaelblegmbh.com
www.KaelbleGmbH.com

ITC - Inter Techno Commerce SA
CH-1920 Martigny, Schweiz
T: +41 277 222 191
F: +41 277 222 185
E: info@itcsa.com
www.itcsa.com