

normet

Normet Oy
Ahmolantie 6
FI-74510 IISALMI, FINLAND
Tel +358 (0) 17 83 241
Fax +358 (0) 17 823 606
info@normet.fi www.normet.fi

Spraymec 7110 WP

Concrete sprayer

TI 100002938
DRW 1700497
DATE 26.02.2013
PAGE 1 / 4

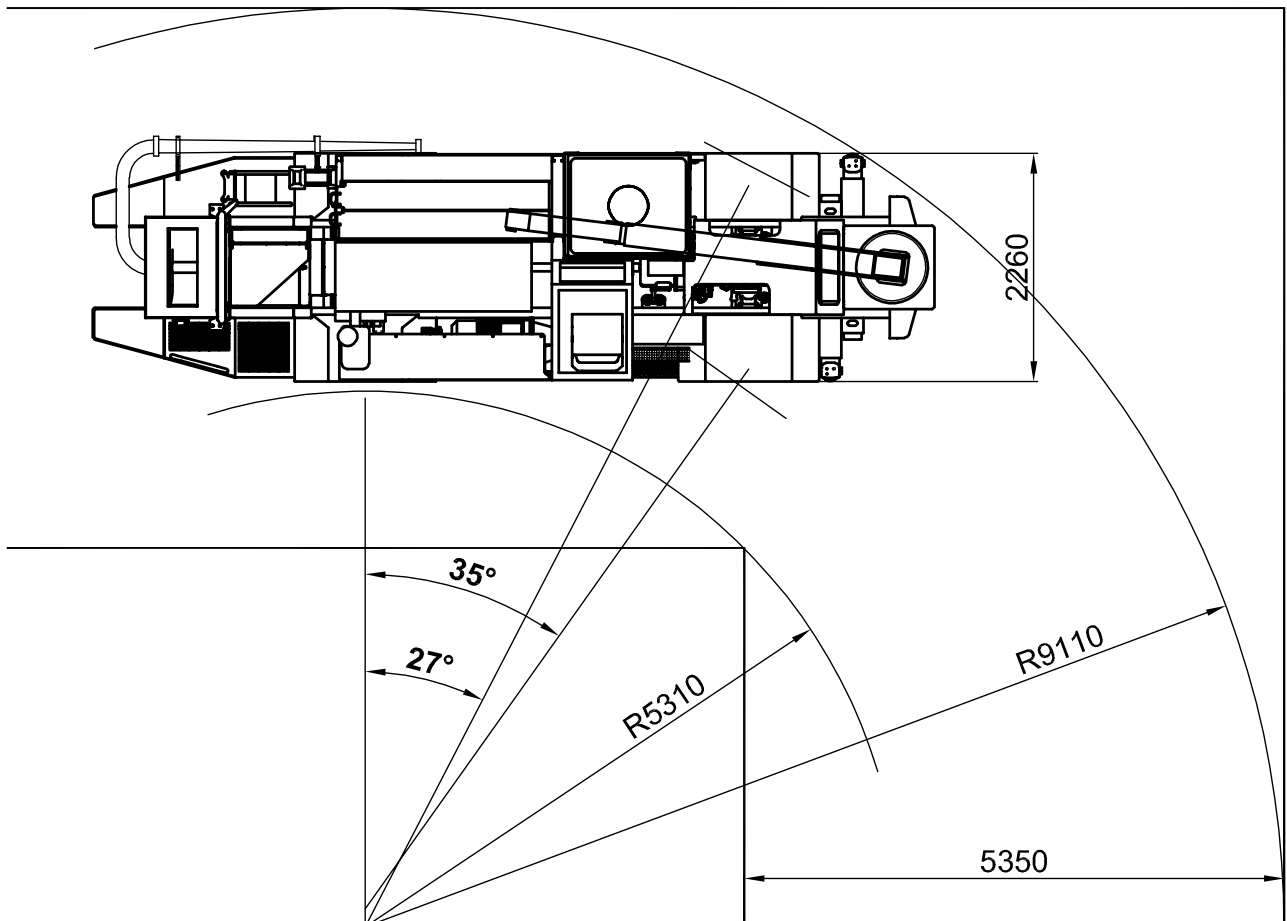
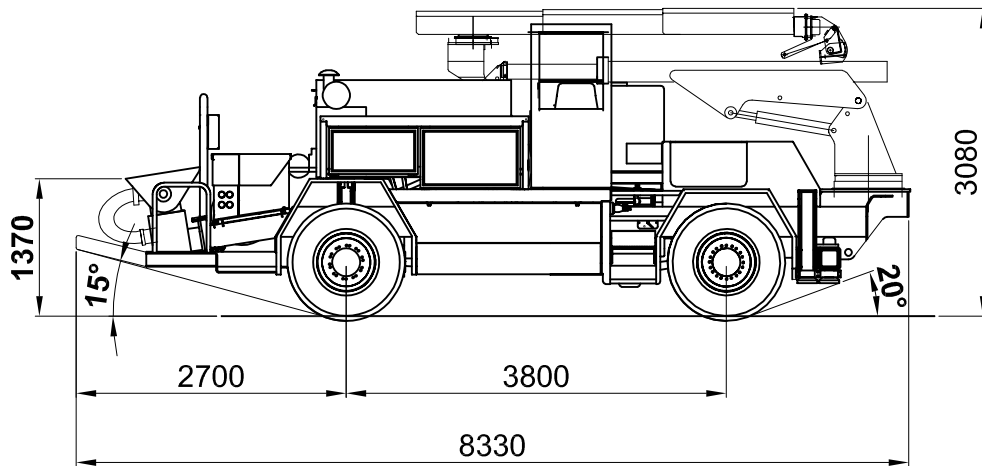

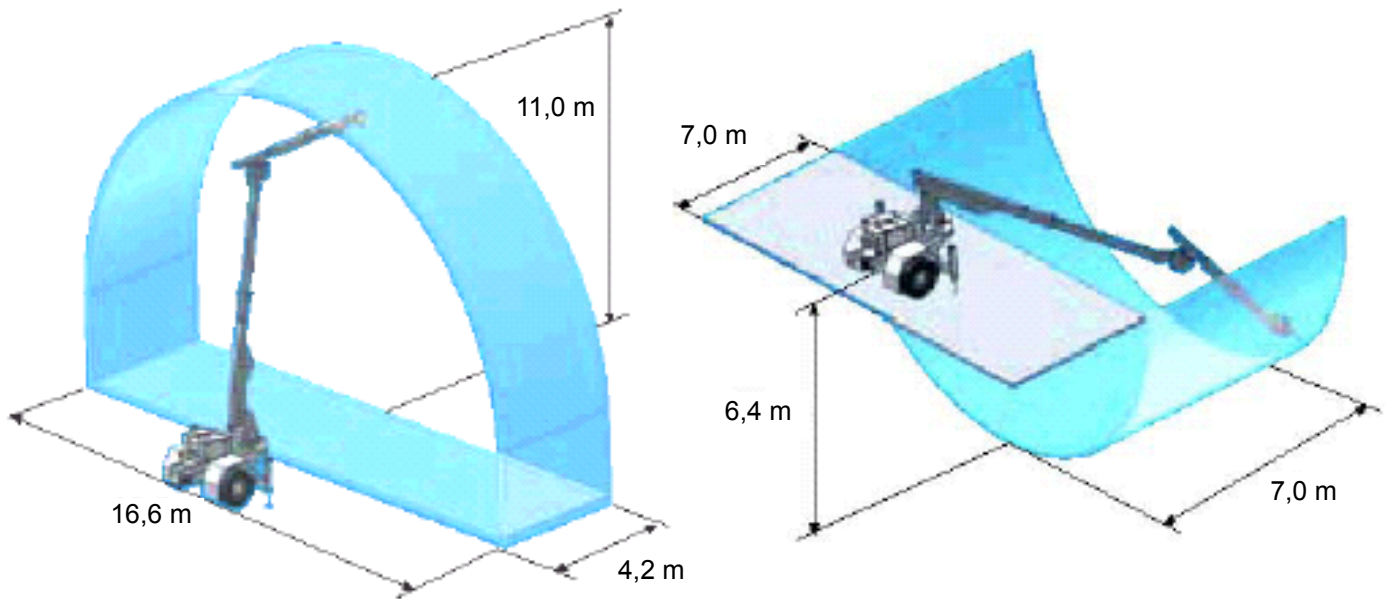
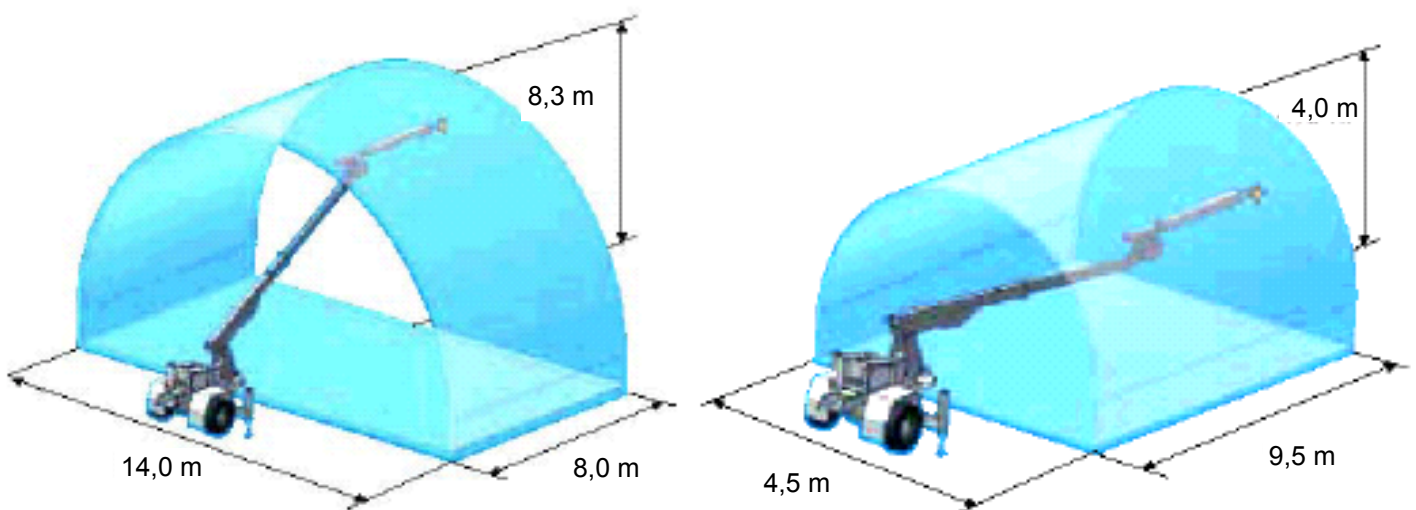
Max. reach**Min. section**

SPRAYMEC 7110 WP

is a self propelled wheel steered unit for power spraying of concrete in underground caverns and tunnels.

DIMENSIONS

Length	8330 mm
Width	2260 mm
Height	3080 mm
Wheel base	3800 mm
Ground clearance	300 mm
Outer turning radius	9110 mm
Inner turning radius	5310 mm
Weight, max. total	14500 kg

1. SPRAYPUMP

is the low-wear and low-maintenance double piston pump with the output of 4-30 m³/hour. Pumping cylinders with a diameter 200 mm, stroke 750 mm and the large suction openings ensure good suctioning, high pumping pressure enable the conveying of stiff concrete consistencies, with a low water/cement ratio max. aggregate size of 16 mm (also crushed) and all types of fibres in the mix.

SPRAYPUMP

Cylinder diameter	200 mm
Cylinder stroke	750 mm
Pumping pressure	57 bar
Pumping capacity	
- theoretical max.	30 m ³ /h
- practical max.	25 m ³ /h

2. ACCELERATOR DOZING SYSTEM NORDOZER 900 H

is designed using wear and corrosion resistant components compatible with all types of liquid accelerators. The accelerator flow is adjustable by manual control, using digital flow meter, from 60 to 900 litres/h

1000 L space for container	
Dosing rate	60 - 900 L/h

3. ELECTRO-HYDRAULIC POWER PACK PPE 550

consist of pumps, oil receiver and filters operates the concrete pump and booms. Boom hydraulics can also be operated diesel-hydraulically.

PPE550	55 kW/400 V 50Hz
--------	------------------

4. SPRAYBOOM SB 510

is of universal type and has the following automatic movements: nozzle rotation, telescopic stroke, vertical and horizontal parallel automatics. These automatic functions help the operator to concentrate on the quality of the spraying process and on minimizing the rebound.

Boom coverages	
- lateral	16 m
- vertical	11 m
Telescopic spraying boom	
- basic boom, stroke	3,0 m
- nozzle boom, stroke	2,2 m
Automatic functions:	
- nozzle rotation	
- horizontal parallel automatics	
- vertical parallel automatics	

5. CABLE REEL KKH35

for power supply of the electrically operated functions, including 100 m of cable.

Power cable	
diam. 3 x 50 mm ² + ground, L = 100 m	

6. SUPPORT LEGS

1 pair in front, hydraulically operated, with lateral extensions.

7. WORKING LIGHTS

At boom end	4 x 70 W
	2 x 1000 W
On carrier	2 x 70 W
	1 x 500 W

 Normet Oy Ahmolantie 6 FI-74510 IISALMI, FINLAND Tel +358 (0) 17 83 241 Fax +358 (0) 17 823 606 info@normet.fi www.normet.fi	Spraymec 7110 WP	TI 100002938 DRW 1700497 DATE 26.02.2013 PAGE 4 / 4
	Concrete sprayer	

8. SAFETY CANOPY

over the drivers seat fulfills the European safety regulations.

9. CARRIER NC 70

Has a rigid chassis and axle steering in boom end. It is specially designed for underground use. Diesel engine with hydro-dynamic transmission and 4-wheel drive gives max. speed of 18 km/h. Fully enclosed multidisc 2-circuit brakes and parking and emergency brake make operating reliable and safe in the harsh underground conditions.

Diesel engine 96 kW
 Driving speed max. 18 km/h

OPTIONAL EQUIPMENT:

690V/50 Hz electrics
 1000V/50 Hz electrics
 Particle filter
 LED driving lights (4 + 2 pcs)
 LED working lights on cabin (2 + 2 pcs)
 Upgrade Nordozer 900 EH
 4-Wheel steering
 Concrete casting kit
 Hydraulic driven water hose reel

ADDITIONAL EQUIPMENT:

Hydraulic driven high pressure washer 180 bar / 30L
 Rock wall washing system 460 bar / 50 L
 Rock wall washing system 180 bar / 90 L
 Electric driven (400V) high pressure washer
 Fogmaker extinguishing system (manual)
 Fogmaker extinguishing system (automatic)
 Ansul extinguishing system (manual)
 Ansul extinguishing system (automatic)
 Tempus manually actuated (Non CE)
 Lubrication system for carrier, boom and pump (Lincoln)
 1 extra hand held fire extinguisher (12 kg)
 Tools for maintenance
 2 pcs wheel chocks with brackets
 Spare wheel
 Admixture warming kit 1500 W
 Admixture container (plastic) 1000 L
 Admixture mixing kit
 Radio remote controlled boom
 Radio control with 4 joystics
 Cooling kit for concrete pump oil
 Iron wheels for container transport
 Form oil system

LTC SERVICES:

SPARE PARTS

Spare parts package A: Available for 1000 h of use*. Include periodical service, most common wearing parts and most critical safety parts.

Spare parts package B: Available for 3000 h of use*. Include periodical service, most common wearing parts and most critical safety parts.

* Recommendations are based on average hours - can vary a lot depending on work site conditions.

TRAINING SERVICES

Available before delivery, at start up and after delivery

Product training:

Operation and Maintenance
 NorSmart
 Foundation of electrics, hydraulics and mechanics
 Audit

Process training:

Concrete spraying
 Charging
 Process audit

AUDIT SERVICES

To improve performance of the machines
 To improve the performance of your processes
 To help improve the quality of maintenance operations

SERVICE CONTRACTS

Spare parts supply programmes
 Scheduled inspection programmes
 Supervision programmes
 Periodic maintenance programmes
 Machine usage programmes

LINK ONE

Link One electronic spare part manuals

WARRANTY SERVICES

Extended warranty